

075. MOTOBALL RULES

&

APPENDIX 076 - MOTOBALL EUROPEAN CHAMPIONSHIP SENIOR + JUNIOR CLASS

+

APPENDIX 077 - Technical Specification SENIOR + JUNIOR CLASS

GENERAL

075.1	Definition	4
075.2	Jurisdiction	4
075.3	Rules	4
075.3.1	Games regulations - automatic sanctions	4
075.4	Motoball meeting classification	4
075.4.1	International matches	4
075.4.2	International interclubs matches	4
075.4.3	National matches	4

FIELD

075.11	Safety measures on the field	5
075.12	Field marking-out	5
075.13	Offside area marking-out	5
075.14	Penalty area marking-out	5
075.15	Penalty spot	5
075.16	Marking-out	6
075.17	Goals	6
075.18	Night matches	6
075.19	Admission on the field	6

ORGANISATION

075.21	To be provided by the organiser	6
075.22	Players	7
075.23	Motorcycles	7

OFFICIALS

075.31	Organiser	8
075.31.1	Jury	8
075.31.2	Referees	8
075.32	Referee's duties	8
075.33	Linesmen	9

BEFORE THE GAME

75.41	Practice	9
75.42	The match	9
75.43	Time to be respected	9
75.44	Price money	10
75.45	Classification	10
75.46	Claims - complaints - protests	10
75.47	Insurance	11
75.48	Applying the rules	11

GAME REGULATIONS

75.51	Players and motorcycles	11
75.52	Players and teams' clothing	12
75.53	Rules applying to the ball	12
75.54	Presentation of the teams at the beginning and at the end of the match	13
75.55	Assigning of the side to each team	13
75.56	Time for the game	13
75.57	Bringing the ball into play	14
75.58	Ball movement	14
75.59	Players' movement	14
75.60	Precedence for passing	14
75.61	Advantage rule	14
75.62	Referee's ball	15
75.63	Rights and duties of the goal-keeper	15
75.64	Goal scored	15
75.65	Offside area rule	15
75.66	Penalty area rule	16
75.67	Faults	16
75.68	Fouls	16
75.70	Penalty kick	16
75.70.1	Faults leading to a penalty	16
75.70.2	Penalty spot	17
75.70.3	Place of the players	17
75.70.4	Penalty kick	17
75.71	Faults leading to a free-kick and rules	18
75.71.1	Free-kicks	19
75.72	Corner	20
75.73	Ball out of the play	20
75.74	Bringing the ball into play on the goal line	20
75.75	Bringing the ball into play from the touch line	20
75.76	Report	21

AUTOMATIC SANCTIONS-FUNCTIONING

75.81	Automatic sanctions	21
75.82	Suspensions	21
75.83	Fines	22
75.84	Team not respecting the presentation to the public at the beginning of the match	22
75.85	Team not respecting the presentation to the public at the end of the match	22
75.86	Team captain refusing to present himself at the end of the match or to sign the report	22
075.87	Team leaving the field during the match	22
75.88	Match stopped by the Referee because a player who has been told to leave the field refuses to do it	22
75.89	Incorrect behaviour from the manager or mechanic towards the Referee	22
75.90	Acts of violence by a player against the Referee	23
75.91	Acts of violence by the manager or mechanic against the Referee	23
75.92	Acts of violence against opponent players, managers, mechanics or spectators	23
75.93	Incorrect acts or insults to opponent players or managers	28
75.94	Spectators on the playing field	23
75.95	Spectators on a neutral field	23
75.96	Incorrect behaviour of a player against the spectators	23
75.97	Incorrect behaviour of a manager or mechanic against the spectators	24
75.98	Delay	24
75.99	Team late on the opponent's field	24
75.100	Player not entering the field by the middle line	24
75.101	Motorcycle not corresponding to the rules	24
75.102	Missing ball(s)	24
75.103	Marking-out not done or badly done	25
75.104	Entries	25
75.105	Friendly and international matches	25
75.106	Players on the touch	25
75.107	Player with a suspended licence	25
75.108	Incomplete team	25
75.109	Match stopped by the Referee because one team or both teams refrain from active sporting play	26

GENERAL

75.1 Definition

A motoball match is a meeting between two teams on a field with the marking out according to the rules and safety measures required.

75.2 Jurisdiction

All motoball matches are to be organised according to the FIM EUROPE Sporting Code regulations and more particularly to these regulations. These regulations must not contain clauses contrary to the FIM EUROPE Sporting Code.

However, should this be the case, the FIM Sporting Code will prevail.

75.3 Rules

75.3.1 Game regulations - automatic sanctions

Under this title enter only precise conditions of each particular match and sanctions applied in case of infringement of these regulations.

75.4 Motoball meeting classification

Motoball meetings are classified in 3 categories:

- 1) International - FIM EUROPE Championships (teams)
- 2) International (interclubs)
- 3) National

75.4.1 International matches

These matches must be played by teams selected by the FMNs. These matches are played according to the FIM EUROPE rules.

75.4.2 International interclubs matches

These matches must be played by club teams after having been authorised by their FMN. These matches are played according to the FIM EUROPE rules.

75.4.3 National matches

These matches must be played by club teams according to a calendar established by the FMN. These matches are played according to the FIM EUROPE rules and Supplementary Regulations of the FMN which are based on the FIM EUROPE rules.

THE FIELD

75.11 Safety measures on the field

The fields on which the motoball matches are played, are the same as that for football matches, including tartan surfaces. In case of international interclubs matches and national matches, the fields made of artificial material may be used if an agreement concerning the surface is made between the clubs of the FMN concerned.

The fields must have a rigid handrail along the sidelines of 2.0 m minimum from the touch line and at 5 m minimum from the goal line. If the distance of 5 m from the goal line is not possible, then extra safety measures must be taken; this is for the spectators and players' safety.

The fence to the left and right behind the goal must be additionally protected by Tire stacks or other suitable protection device.

75.12 Field marking-out

This is the minimum standards for the fields, identical to a football field.

Maximum length: 110 meters - Maximum width: 75 meters.

Minimum length: 85 meters - Minimum width: 45 meters.

Goal lines at each end of the field. Touch lines perpendicular to the goal line. Medium line equidistant from the goal lines. On this line, exactly in the middle, is the centre of the circle which has a radius of 18.30 m, called the circle of the centre.

On the corners of the field white or yellow corner-flags, 0.60 x 0.60 m, on a flexible pole with a minimum height of 1.50 m must be placed.

If the length and the width of the field are less than the minimum, this must be specified in the Supplementary Regulations.

75.13 Offside area marking-out

The offside area has the shape of a semi-circle with a radius of 5.75 m, measured from the point halfway between the two goal-posts.

75.14 Penalty area marking-out

It consists of a rectangle, the base of which must form a part of the goal line. The furthestmost points lie 16.45 m beside the goal posts.

At these two points two lines of 16.45 m long each are drawn perpendicular to the goal lines. The extremities of these lines are joined by a line parallel to the goal line.

75.15 Penalty spot

In each penalty area a penalty spot placed on an imaginary line perpendicular to the goal line is marked out at 11 m from the middle of the goal line.

75.16 Marking-out

The field must be marked out by white lines with a minimum width of 12 cm. The medium line must have a minimum width of 24 cm. Bright colours are permitted, should white not be available.

A field marked-out by drains is forbidden. If the marking-out is not in accordance with the rules, then the match is lost for the receiving team. In that case a friendly match will have to be played unless a club is able to comply with these rules.

75.17 Goals

The goal must be painted white and provided with nets fixed onto the ground. Goals dimensions: width 7.32 m and height 2.44 . The goal must be of a strong construction. The goal-posts must be cylindrical. The goal-posts must have a maximum diameter of 12 cm and a minimum diameter of 10 cm.

75.18 Night matches

Matches may be played at night provided the field is correctly lighted. Minimum of 200 lux on the whole field. Matches may not be played if the field is not sufficiently lighted, in which case the organising club will have to pay the visiting club the agreed indemnity.

If an official match is cancelled because of insufficient lighting, the match will be lost by default for the organising club.

Only the Referees will decide if the light-intensity is sufficient and if the match is to be played or not. The ball used during night-matches must be white.

75.19 Admission on the field

It is unauthorised for persons to be between the playing-field and the handrails with the exception of the players, the Referees and the linesmen.

ORGANISATION**75.21 To be provided by the organiser**

The following must be provided by the organiser of the match:

- A number of stewards provided with an armband to preserve order.
- One steward is to be in charge of accompanying the Referees.
- A well equipped first aid kit in each mechanic area.
- A stretcher.
- A fire-extinguisher in each mechanic area.
- Hot and cold water.

- The mechanic area is situated behind the goal line on the corner, except when permanent pits have been built.

Any infringement of these above mentioned items will be written in the report and any infringement to these regulations may be penalised.

75.22 Players

Players may only be allowed to compete if they are in possession of a:

Senior : FIM Europe Motoball One Event Continental Promotional Annual Continental licence. To be eligible, a player must be at least 16 years old.

Junior: FIM Europe Motoball Promotional One Event Continental licence (also the Promotional Annual licence is accepted, being "superior").

- It is open to riders that get 12 years of age and who are under, or reach 18 years during the year of the even
- legs must be protected by knee-length boots. Leather (or material similar to leather) leggings. Shoes and boots may not endanger other players; such to be judged by the Referees.
- leather (or material similar to leather) gloves must be worn.
- a helmet in good condition which has been approved by the FMN in accordance to the FIM standards.
- the team's helmets must be of the same colour.

75.23 Motorcycles

Motorcycles must neither have a cubic capacity superior to 250 cc nor be more than 2.2 m long. Their minimum weight is 70 kg and maximum weight is 120 kg, without fuel or battery, E-Bikes are allowed.

The motorcycles may not have any unnecessary accessories or parts which could disturb other players or which by their shape, asperity or position be a danger to the players or damage the ball.

Motorcycles must be provided with a silencer. The noise level must not exceed 98 dBA (to be measured according to Appendix 01 - FIM EUROPE Technical rules).

Motorcycles may not produce exhaustive fumes. The back-stand and mechanic adding, which could carry the ball along without use of the foot, and reverse handlebars are forbidden.

The maximum width of the handlebars is 70 cm; the installed levers may not protrude. All protruding parts, ends of handles, handlebars must be protected with rubber or metal balls with a minimum diameter of 15 mm.

The motorcycle must be provided with 2 chain-guards: the superior one going from the gearbox to the back wheel axis; the inferior one, at least 10 cm long, protecting the chain from being touched on the back wheel sprocket. The latter



may be substituted by a protecting plate, fixed onto the outside of the motorcycle.

It is strongly recommended to protect the engine by an extra bar so that no parts, e.g. footrests, brakes etc..., are able to protrude outside the bar. If a mudguard is attached, then the space between the tyre and the mudguard may not be more than 10 cm.

On the rear wheel only Trial or Speedway tyres may be used which have a distance of profile less than the other. The choice is free for the tyre used on the front wheel. Casted wheels are forbidden.

Motorcycles which do not comply with these regulations may not be used in the matches.

Any infringement to this article will be punished according to the stated automatic sanctions.

OFFICIALS

075.31 Organiser

Organisers can only be affiliated to an FMN or act on behalf of a club affiliated to an FMN. They are completely responsible towards the FMN for the general organisation of any match.

75.31.1 Jury

Composition of the Jury:

Organiser, and Referees from both participating teams one of them is Jury member.

75.31.2 Referees

The sporting part of the match is controlled by two Referees. They are nominated by the FMN and must have a Referee's licence issued by the FIM EUROPE or the FMN and should be dressed in white sporting clothes or azur blue or yellow with FIM EUROPE Logo and socks in the same colour and black pants.

75.32 Referees' duties

A Referee must be at least 18 years old.

The competence (supervision and right to penalise) of the Referees covers a period from one hour before the match until 30 minutes after the match. A Referee who is a spectator at a match must, if a Referee is absent and if this is an official match may take the place of the absent Referee even if he is without whistle or outfit. The club responsible for the organisation must furnish these items. In case of refusal, he will be suspended and in case of repetition of the offence, his licence will be withdrawn.

If there is only one Referee on the field, then each club must present one Referee and the drawing of lots will indicate which one will be the official Referee. If there is no Referee on the field then each club nominates one Referee. If this is impossible then the organising club must present the Referees Official matches (night matches and friendly matches) are directed by two Referees. At each match between teams with different nationalities, a Referee must be nominated by each national team.

75.33 Linesmen

Two linesmen must be nominated.

Except in cases of divergence from the Supplementary Regulations for a match, each club shall nominate one linesman. Before the match, each team must bring onto the field a linesman dressed in white or azur blue or yellow. By default, the Referees will appoint one of the two reserves players and that team will then have to play with one less reserve player.

A linesman must be at least 16 years old. It is the duty of a linesman to indicate by means of a yellow or yellow/red flag the following:

- if the ball completely passes the side of the goal line and which team has to restart the game.
- if a player passes the centre line while in possession of the ball.
- if a player plays the ball over the centre line and after crossing the centre line regains possession of the ball or touches the ball with his motorcycle before another player or motorcycle has touched the ball.

A linesman may be replaced if, according to the Referees, he does not perform his duties correctly. After being removed by the Referees, the linesman must be replaced by a qualified Referee, manager or reserve player of the same team.

BEFORE THE GAME

75.41 Practice

The field must be available at least 30 minutes before the kick-off to allow the players to have a minimum of 15 minutes practice and to try out their machines.

Practice is not allowed 15 minutes before the start of the match.

75.42 The match

It is divided in four periods of 20 minutes each, separated by a 10 minute break. Between the second and the third period, the teams change side.

If a different format is used, then this must be stated in the Supplementary Regulations.

75.43 Time to be respected

The normal time for the kick-off must be decided beforehand. In the 12 days preceding the match the organising club must inform the visiting club and the Referees to confirm or modify this time.

The Referees must write on their report the exact time of the kick-off. They indicate if there is a delay and the name of the team responsible. A club which is late, for any reason, must immediately inform either by telephone, text message or e-mail the other team or the organiser.

In case of a long delay caused, for example, by a serious accident, the match will be postponed to a later date. The club in fault will have to reimburse to the organiser the expenses of the team. No sanctions will be applied in case of an unintentional delay of a team if the opponent team makes no complaint. The captain or the manager of the team must show the licences of his players to the Referees 40 minutes before the start of the match. The captain must sign the report of the Referees within 30 minutes after the finish of the match.

If a match is stopped by the Referees, because of "force majeure", before the finish of the third period, then the match must be replayed. If the match is stopped by the Referees after the third period, then the match will be considered as having finished and the score at that moment will be considered as the final score.

A team has lost the match by 3-0 if:

- it fails to appear without giving reasons.
- the field and the accommodation do not comply with the regulations.
- the team leaves the field during the match (see Art. 075.87).
- the team brings a rejected motorcycle onto the field during the match.
- the team brings a player onto the field who is not qualified to play in the team (see Art. 075.109).

75.44 Price Money

The prices given to teams playing friendly matches are established after an agreement between the clubs.

75.45 Classification

The classification of the official matches is made according to the matches either by the addition of points or by elimination.

75.46 Protests and appeals

Time limits for presenting a protest:

Each protest must refer to a single subject only and must be presented within half an hour (30 minutes), at the latest, after the publication of the results, unless otherwise provided for in the Sporting Rules. The protest fee is € 350.

Time limits for the lodging of an appeal:

against a decision of the Jury or referee	5 days	fee € 650
against a decision of the Disciplinary Commission	5 days	fee established by FIM.

75.47 Insurance

The club organising a Motoball match must have been insured to guarantee the club, teams and officials against liability. This includes bodily and material accidents caused to a third party and bodily harm caused to other sportsmen during practice or during the competition supervised by the club. The right to play can be refused if they are not insured as described above.

75.48 Applying the rules

When making a contract (membership-licence), clubs and players declare that they acknowledge these rules and promise to comply with them. Any point not stated in these rules will be settled according to the FIM EUROPE international regulations or the national sport regulations of the FMNR.

The Motoball Working Group and the FMNs can recommend additional clauses. This Appendix applies for all Motoball matches.

GAME REGULATIONS

75.51 Players and motorcycles

There are 10 players in a Motoball team, 2 mechanics and 1 manager. A team may use a maximum of 10 motorcycles during a match. There are 5 players in each team; 4 riders and 1 goal-keeper. The reserve players must wait in the pits.

Before the match, each team must present the captain to the Referees. The titular captain must wear on his left-arm an armband coloured differently from his jersey.

The substitute captain takes the place of the titular captain if he is out for any reasons (violent game etc...). If both are out, then the team must present another captain to the Referees. If this is not done the Referee will nominate a player for this function. In case of refusal the Referee will disregard any protests.

After agreement between the two teams, they may present on the field as many machines as they like as long as this number is not less than 5 and not more than 10. If the Referees agree, anyone of the players may take the place of the injured goal-keeper. The substitute may only enter by the centre of the field. He must not stop on the centre of the field with his engine running. The same goes for any player who has gone to the mechanic area or who has any repairing done in a different place.

Except for the goal-keeper who is not obliged to enter by the centre of the field.

Any infringement of this rule is penalised by a free-kick on the point where the player irregularly entered the field. The substitute and the substituted are not allowed to be on the field at the same time. For any infringement of this rule the Referees will penalise the substitute and the substituted by sending them to the touch line for 2 minute (green card) which does not prevent the free-kick against the team at fault. If

it is not clear to the Referees which player is to be substituted, a player may be appointed by the captain of that team.

The automatic sanctions, Art. 075.102, are added to these sanctions. If there are less than 3 players in a team they cannot continue playing if it is an official match (see further Art. 075.56). However a team must present itself with at least 5 players, if not they will lose by default. They will have to play a friendly match if it was an official match and if there are 4 players. In these cases Art. 075.110 of the automatic sanctions must be applied.

75.52 Players and team's clothing

Each player must wear a shirt of the same colour as the club, except the goal-keeper whose shirt has a different colour from the rest of the players. In case of similar colours, the visiting team will change its colours, to be provided by the receiving team. In case of a game on a neutral field, the nearest team will be considered as the receiving team, or, after an agreement between the teams, by drawing of lots. They may never be dressed in white.

Each player must have a number on the back of his shirt. The team must give consecutive numbers to its players. The numbers must be clearly visible, have a minimum height of 15 cm and a minimum width of 19 cm and be of contrasting colour. The width of the number's figure must be 5 cm.

75.53 Rules applying to the ball

The ball is a rubber bladder covered with leather or equivalent material. The circumference is of 119 cm minimum and 126 cm maximum. Its minimum weight is 900 gr and maximum 1200 gr, to be weighed before the match. Each team must present 2 balls in good condition. A ball of each team must be used for half a match. The visiting team will furnish the ball for the 1st and 2nd periods and the receiving team for the 3rd and 4th periods. The ball used during night-matches must be white.

In case of extra-time playing, the visiting team will furnish the ball for the 1st period and the receiving team for the 2nd period.

75.54 Presentation of the teams at the beginning and at the end of the match

For the presentation the teams must necessarily start from the mechanic area and go to the centre of the field; they must stand in line parallel to the touch line facing the officials. The drawing of the lots takes place and by order of the Referees, they ride around the field for their presentation to the spectators with the captain leading.

When the match is finished, the teams must again present themselves to the officials and make a lap of honour around the field side by side, the winning team on the side of the spectators. Presentation to the spectators is compulsory even if the team is incomplete. This presentation must take place immediately after the final whistle. In case of non-observance of the rule, the team in fault is penalised according to the automatic sanctions (see Art. 075.84 & 075.85).

75.55 Assigning of the side to each team

This is done by the drawing of lots at the beginning of the match and by changing sides between the 2nd and the 3rd period. The winning of the toss gives the captain the choice between the kickoff or the side.

75.56 Time for the game

The match is divided into 4 periods of 20 minutes. They are separated by a ten minute break. Under no circumstances may the Referee change the rest time. Between the 2nd and the 3rd period the teams change side. When the Referee sees that there are only 2 players of a team left on the field, he whistles indicating an idle period. In this case he may suspend the match for a 10 minute break. A team may have only one of these breaks. If this reoccurs the Referee stops the official match and makes it a friendly match.

In case of a draw, in a Cup or Championship match, and if it is provided for in the Supplementary Regulations, the Referee must give 10 minutes extra time twice, each one separated by a 5 minute break. Before the kick-off of this extra-time, a new drawing of lots for the side is compulsory.

The Referees must take into account the idle periods which occurred during the match and prolong the match accordingly. They must write in the report if the time for the kick-off has been respected (see Art. 075.100).

75.57 Bringing the ball into play

The match starts as follow:

The ball is placed in the centre of the field. The 3 forwards, who benefit from a kick-off, go behind the middle line; their front wheel can touch this line. The players of the other team must be outside the line of the circle of their side. The goal-keepers are in their goal area.

At the Referees' first whistle a player starts the game with a forward kick of the foot. The ball must cover a distance of 1.5 m in the opposite side. He may touch the ball again only if it has first been touched by another player. The opponent players may move towards the ball only when it has been kicked and has covered a distance of 1.5m.

75.58 Ball movement

The movement is given to the ball with the foot by a player on his machine (the engine must be running) either by a succession of different kicks or by a continuous pushing (the ball must not be carried) or by a shock given with the head or the body or with any part of the motorcycle. Apart from the goal-keeper in the offside area, the players must not use their hands or arms.

Each time the ball is put into the game, in the centre of the field, for a free kick or for a ball out of touch, it must be done with a kick of the foot. The ball may not be followed by the same player. It is forbidden for 2 players of the same team to ride closer than 1.5 m next to each other if they have the ball between them.

75.59 Players' movement

The players may not move on the whole surface of the field. The offside area is forbidden for all players except the goal-keeper (see Art. 075.67/075.68). A player may not cross the middle line with the ball. He must first let it roll and can touch it again when it has been touched by another player or another motorcycle.

The players may move the ball in every direction.

The fault is penalised by a free kick on the middle line against the side of the player at fault.

75.60 Precedence for passing

It is forbidden to bar the way of a player with or without the ball. A moving player may only be attacked on the side where the ball is. A moving player on the wrong side must allow the player with the ball to move in every direction. In case of 2 players converging towards the same point it is the one with the ball who has precedence. Being in possession of the ball is a player who manoeuvres it by pushing it with his foot or his leg. This right stops as soon as another player has touched the ball and keeps it or passes it to another player. A player attacking another player who is carrying the ball may only take over the ball using his foot or leg.

A player in possession of the ball is at fault if he voluntarily changes direction so as to put in fault the player in back position.

75.61 Advantage rule

When a player in possession of the ball is irregularly attacked by an opponent and keeps the ball, the game may not be stopped for this fault. When the ball goes out of the field and the Referee cannot exactly determine which team is to bring the ball into play again, this is done by the team of the side on which the kick-off took place. When an attacking player or another player of his team stays in the possession of the ball, there is no danger if he plays further and he has not made an important break of the rules, then the Referee has to apply the advantage rule. In all other cases the Referee will not penalise, if by doing so, he gives an advantage to the team that committed the fault.

75.62 Referee's ball

The Referee takes the ball approximately 10 seconds after the game has been stopped and lets the ball fall vertically from arm's height between 2 players who are separated from one another by 2 m. The other players are 9.15 m from the ball; the motorcycles may only move after the ball has touched the ground. No Referee's ball may be given in the penalty area.

75.63 Rights and duties of the goal-keeper

Playing in the offside area, the goal-keeper may use his hands to handle the ball. The goalkeeper who comes outside this area with any part of his body during the

game will be penalised by a free-kick on the 16.45 m line parallel to the goal from the spot nearest to where the fault was made. With an overhead ball, the freeing of it by hands is tolerated on the condition that his feet are in his playing area.

The goal-keeper must bring the ball back into play within 10 seconds. If not he will be penalised with a free-kick on the 16.45 m line against him. The ball may not be given directly back to the goal-keeper before the player with the ball has passed the 16.45 m line. Penalty: free-kick.

75.64 Goal scored

A goal is scored when the ball entirely passes the line between the posts. If the ball enters the goal and the Referee sees that it has burst, he refuses the goal and starts again with a Referee's ball on the 16.45 m line on the side concerned.

If the ball bursts in the case of a free-kick then the free-kick will be repeated. If no goals are scored or in case of a tie, the match is a draw.

75.65 Offside area rule

This area is described in Art. 075.13.

The marking-out of this area is compared to a wall; no part of the motorcycle may go beyond it. This area is forbidden for all players except the goal-keeper. In case of infringement a free-kick at the 16.45 m line is given against the player at fault. If a goal is scored by an attacking player at fault, the goal will not be counted.

A defending player deliberately entering this area to save a goal, when the goal-keeper is defeated, will be penalised by a penalty if the goal is saved. If the goal is scored in spite of him, it is counted. A free-kick spot is determined by an imaginary line perpendicular to the goal line, starting from the point where the fault was committed.

If an attacking player deliberately rides into the offside area or he touches the goal-keeper inside the offside area a penalty is given at the opposite goal. If a defending player voluntarily or not makes an attacking player enter the offside area, he is penalised according to the fault, either by a penalty or by a free-kick against his side. If a goal is scored during his entering the area, it is counted for his team and the penalty or the free-kick is cancelled.

75.66 Penalty area rule

It consists of a rectangle whose base is the part of the goal line between 2 points placed on each side of the goal at 16.45 m from the posts. The other sides of the rectangle are obtained by drawing from the extremities of the base 2 perpendiculars to the goal line, 16.45 m long, whose extremities are joined by a line parallel to the goal line.

For a fault causing a free-kick in the penalty area, the ball is placed on the line parallel to the goal marking out this area as near as possible to the place where the fault was committed.

75.67 Faults

There is a fault and a reason to penalise when a player kicks the ball:

- without riding his motorcycle
- with his engine stopped
- with his hands (except the goal-keeper)
- when he bars the way of a player with or without the ball.

75.68 Fouls

Any player having engine trouble may not remain on the field. There is obstruction if a player of a penalised team, though respecting the distance of 9.15 m from the ball, goes to the side of the team benefiting from the free-kick, so that he disturbs in the direction of the player who is about to take the free-kick. In this case the free-kick may only be given when all the players are in the regular position. If a player refuses to place himself according to the regulations, the article of the automatic sanctions is applied.

Any team voluntarily leaving the field during the game has lost the match with a minimum score of 3-0. If the difference in the score is superior to 3-0 when the team leaves, it is kept.

75.70 Penalty kicks

75.70.1 Faults leading to a penalty

Penalised by a penalty are the following faults, committed by a player on his own penalty area:

- a player entering the offside area to save a goal when the goal-keeper is defeated – the penalty is given if the goal is saved.
- playing the ball with hands or arms on purpose (except the goal-keeper).
- rough play (hitting an opponent with fist or foot).
- holding or pushing with force an opponent or his motorcycle.
- the attacking player deliberately entering the offside area and he touches the goal-keeper - the penalty kick is given at the opposite goal.
- a player who is attacked from two other players of the other team.
- voluntarily departure of the goal-keeper during the game, from his playing area.

75.70.2 Penalty spot

A spot marked on an (imaginary) perpendicular drawn from the middle of the goal line at a distance of 11 m from the goal line, is the penalty spot from which the penalty kick will be taken.

75.70.3 Place of the players

They must all be inside the field, outside the penalty area, except the goal-keeper and the player taking the penalty kick; the other players must be at least 9.15 m from the ball.

The goal-keeper must remain on the goal line, between the posts. He may however stand wherever he likes on this line. He may not move between the moment the Referee whistles and he penalty kick is taken.

In case of infringement of this rule, if the goal is scored, it is counted; if not, the penalty kick must be taken again.

75.70.4 Penalty kick

The penalty kick must be made by a player present on the field at the time of the fault.

The player must kick the ball forwards. The players may only enter the penalty area after the ball has been kicked. Any fault made by the defending team the penalty kick must be taken again if the goal has not been scored. Any fault made by the attacking team, by a different player from the one kicking the ball, the penalty kick is taken again if a goal has been scored. Any fault made by both teams, the penalty kick is taken again, whatever the result.

The player who takes the penalty kick must kick it forward and may not touch it again before another player has touched it. In case of non-observance of this rule, a free-kick is given to the opponent team.

If necessary the game is prolonged to allow the penalty kick to be taken. In this case the goal scored is counted, but if the goal-keeper effects a save, or the ball goes out to touch the bar, the game is ended. In this case only the goal-keeper and the player taking the penalty kick may remain on the field.

75.71 Faults leading to a free-kick and rules

A free-kick is given to a player at fault for the following faults:

- crossing the middle line with the ball.
- barring the way of a player with or without the ball.
- playing with hands or arms outside the penalty area (except the goal-keeper in the Offside area and the players who have their hands for protection on the helmet, but they are not allowed to move their hands, otherwise a penalty-kick will be given).
- jamming the ball with the motorcycle.
- carrying the ball with the hand or holding it between the leg and the motorcycle.
- playing the ball without sitting or standing on the motorcycle.
- dangerous play; the 1st time the player will receive a green card. In case of

repetition the Referee will give a yellow, yellow/red or a red card.

- a defending player forcing an attacking one into the offside area.
- a player forcing an attacking from the wrong side.
- If a referee see that a team with the ball have a long time (60 sec.) no intention to attack the referee give a sign to his clock to the player that he interrupt after 15 sec. the match. The same is also for the cross of the middle line.
- a goal-keeper voluntarily holding the ball in the offside area for more than 10 seconds.
- the goal-keeper receiving the ball directly back before the player with the ball has passed the 16.45 m line parallel to the goal-line (see Art. 075.63).
- a goal-keeper left the offside area .
- using hands to hold an attacking player or his motorcycle.
- playing again after the free-kick.
- playing again after the kick-off.
- giving the ball to the goal-keeper and then riding behind the goal and receiving the ball back on the other side.
- substitute and substituted player on the field together.
- irregular entering the offside area (see Art. 075.65).
- obvious obstruction, even without having the ball.
- dangerous play when a rider deliberately crashes into an opponent's motorcycle or when lifting a foot higher than the handlebars.
- placing a foot in front of an opponent's wheel.
- 2 players of the same team keeping the ball between them without taking into account the regulated distance of 1.5 m.
- entering the field somewhere else than in the centre.
- obstructing an opponent without having the intention to play the ball.
- taking part in the match on a motorcycle with the engine stopped.
- moving the motorcycle backwards.
- a goal-keeper coming outside the offside area while the match is being played.

- faults in case of Arts. 075.90, 075.92, 075.94, 075.95 & 075.98.
- the player in the wall not sitting on his motorcycle.
- a player keeping the ball too long without any attempt of playing.

75.71.1 Free-kicks

Any free-kick counts if it enters directly into the goal. The free-kick will be taken after the Referee put the ball on the right spot and release it by a whistle. No opponent player may go at less than 9.15 m from the ball, before it has been kicked.

The free-kick may only be made by a player present on the field at the time of the fault.

The player kicking the ball must be riding his motorcycle. He may only touch the ball again when the ball has been touched by another player or another motorcycle. It is forbidden to obstruct the player taking the free-kick, to ride or stand in the way. The free-kick may be taken in any direction, only after the Referee's whistle.

A free-kick inside the penalty area is brought back to 16.45 m. The ball is then placed on the line parallel to the goal marking out the penalty area as near as possible to the spot where the fault was committed. If a free-kick is taken by an attacking player on the penalty area line then all players who are in the penalty area must remain seated on their motorcycles and remain stationary until the free-kick has been taken.

If a defending player does not follow this rule, then any goal scored will count. If no goal is scored then the free-kick may be taken again. If an attacking player does not follow this rule, then the game will be stopped and the free-kick will be given to the defending team, to be taken from the penalty area line.

If a player taking the free-kick rides into a player of the defending team who is in the penalty area and who has not changed his position while the free-kick was being taken, then any goal scored will not be counted and a free-kick will be given to the defending team, to be taken from the penalty area line.

When there is a free kick at their own half, every defender has to be between the ball and the goal. It is possible for a player to take the free kick in a cross angle.

75.72 Corner

When the ball is sent behind the goal line by a player of the side to which this line belongs, the ball is placed in the game at the crossing of the goal line and the penalty area line. No opponent may be less than 9.15 m from the ball before it has been kicked.

If this rule is not observed then the corner is retaken after the Referee has warned the player to observe the regulations. The player kicking the ball may only touch it again after it has been touched by another player or another motorcycle. The players may move as long as they respect the distance of 9.15 m. No prolongation can be given for a corner kick.

75.73 Ball out of the play

The ball is out if it entirely crosses either on the ground or in the air the goal line somewhere else than between the posts or the touch line. The ball is not out if, after touching the Referee, a linesman, a post or the bar of the goal, it comes back on the field.

75.74 Bringing the ball into play on the goal line

When a ball is sent beyond the goal line by a player of the attacking team, it is brought into play by the goal-keeper of the team to which this line belongs.

During the kick-off the opponents have to be outside the 16.45 m area until the Referee has whistled and the ball has been kicked and has come outside the 16.45 m. area. The ball may not remain more than 10 seconds in the penalty area after the Referee has whistled and may not be passed directly back to the goal-keeper.

75.75 Bringing the ball into play from the touch line

If the ball has passed the touch line, a player of the opponent team to the player who has last touched the ball, brings the ball into play again from the spot where the ball passed the touched line. This is done by a kick of the foot by a player who is outside the field and has his engine running.

The opponents must be 9.15 m from the spot where the ball is brought into play. They may not move until the ball has been kicked and covered a distance of 1.5 m. A player may not touch the ball twice.

If this is not carried out correctly then an opponent player may bring the ball into play. If a player who brings the ball into play touches the ball twice, a free-kick is given against his team.

75.76 Report

Before each match the appointed Referee writes in the report the players' names, their licence numbers, the team captain and the reserve players. After the match, he writes down the results, the important acts and the sanctions taken. He also records any protests made.

The report must be signed by the responsible Referee and the 2 captains. If one or both captains refuse to sign the report, the Referee must record it in the report so that automatic sanctions may be applied (see Art. 075.86).

FUNCTIONING AUTOMATIC SANCTIONS

75.81 Automatic sanctions

All automatic sanctions apply for a period of 1 year. The automatic sanctions must be made known to the FMNs and the clubs; but, the managers are responsible for their applications. Any sanction not applied within the time allowed is doubled.

An infringement leading to an automatic sanction must be recorded in the report and the Referee must inform the team manager of the faults and the facts and indicate to which article of the automatic sanctions the fault corresponds. The captain of the team at fault must, before signing the report, write: Read and noted.

The precise facts may then be recorded in a report written by the Referee; either on the back of the report (and not signed by the captain) or in a separate letter joined to it.

The complete reports must be sent to the federation to which the club or the organising team is affiliated, within 24 hours. The automatic sanctions will generally be confirmed by letter from the FMNR. If, for any reason, the confirmation is not sent, then the automatic sanctions must still be applied under the responsibility of the manager of the team.

75.82 Suspensions

According to the regulations of the FIM EUROPE, any player, manager or team which has been suspended, must send their licence to the affiliated FMN. It will be returned after the time decided for suspension. Any delay in sending the licence will be added to the suspension time.

If a Referee show a red card, the player is suspend for this and the next match; and is it in the final-match, the player will be suspend for the next ECS-match and perhaps more sanctions through FIM EUROPE.

75.83 Fines

Fines must be paid within 15 days following the match to the FMNR. Any delay in the payment of the fine will lead to a suspension until the fine has been paid.

All the fines mentioned in the articles below must be applied by the Jury. The Jury is allowed to take further action, but only in connection with Art. 3.4 of the Disciplinary and Arbitration Code.

75.84 Teams not respecting the presentation to the public at the beginning of the match (Art. 075.54)

Even an incomplete team (minimum 4 players) must carry out this duty.

Fine: 30 euro.- per match.

75.85 Teams not respecting the presentation to the public at the end of the match (Art. 075.54)

Even an incomplete team must carry out this duty. In case of a complete breakdown of the machines, they must walk immediately after the final whistle.

Fine: 30 euro.- per match.

75.86 Team captain refusing to present himself at the end of the match or to sign the report

1st time: suspension for the next match.
2nd time: suspension for 3 matches.

75.87 Team leaving the field during a match

Match lost with a minimum score 3-0. If the score is higher than 3-0 when the team leaves the field, this score is kept for the team still playing. The team leaving the field is considered as defeated by default. Fine: euro 500.-.

In case the visiting team leaves the field, its indemnity will be blocked. In case of repetition, a suspension and a withdrawal of players' and team licences.

75.88 Match stopped by the Referee because a player who has been told to leave the field refuses to do it

A player who has been told by the Referee to leave the field for some time or until the end of the match and who refuses to do so, forces the Referee to stop the match. This player's team will have lost the match by default without prejudice to the automatic sanctions. This case is assimilated to Art. 075.87.

75.89 Incorrect behaviour from the manager or mechanic towards the Referee

1st time: Fine for the team: EUR 30.-.

2nd time: Fine for the team: EUR 60.

3rd time: Fine for the team: EUR 90.-.

75.90 Acts of violence by a player against the Referee

"Sine die" suspension.

75.91 Acts of violence by the manager and/or mechanic against the Referee

"Sine die" suspension.

75.92 Acts of violence against opponent players, managers, mechanics or spectators

1st time: suspension for the next 2 international matches.

2nd time: suspension for the next 4 international matches.

3rd time: suspension for a year. Fine for the player: EURO 60.-.

In case of a dispute between 2 players, the Referee, if necessary settle the dispute.

75.93 Incorrect acts or insults to opponent players or managers

1st time: Fine for the team: EURO

30.-. 2nd time: Fine for the team: EURO 60.-.

3rd time: suspension of the player for the next international match. Fine for the team: EURO 90.-.

75.94 Spectators on the playing field

This article concerns the organising club.

In case of a match between 2 teams representing the national selection, the respective FMNs will study the dispute.

1st time: fine for the club: EURO 60.-. 2nd time: fine for the club: EURO 90.-.

Suspension of the field for the next international match.

75.95 Spectators on a neutral field

This article concerns clubs punished according to Art. 075.96.

Fine: EURO 200.- for the club responsible for the organisation of an official match on a neutral field. If a club is penalised for a suspension of a field, it must organise the match on a neutral field outside its locality.

75.96 Incorrect behaviour of a player against the spectators

1st time: suspension for the next international match.
2nd time: suspension for the next 2 international matches.
Fine for the player: EURO 30.-.
3rd time: suspension for the rest of the season.
Fine for the player: EURO 60.-.

75.97 Incorrect behaviour of the manager or mechanic against the spectators

1st time: fine for the team: EURO 30.-.
2nd time: fine for the team: EURO 60.-.
3rd time: fine for the team: EURO 90.-.

Incorrect behaviour against spectators may only be taken into account if a delegate of the federation or one of the Referees has witnessed it.

75.98 Delay

Fine for the team responsible for the organisation of the match which starts too late:

from 15 to 30 minutes: EURO 30.-.

from 30 to 45 minutes: EURO 60.-.

For more than 45 minutes the organising club will lose by default.

75.99 Team late on the opponent's field

Team late on the opponent's field according to the time decided for the kick-off by the organiser:

from 15 to 30 minutes: EURO 30.-.

from 30 to 45 minutes: EURO 60.-.

For more than 45 minutes the team late on the opponent's field will lose by default.

75.100 Player not entering the field by the middle line

1st time: green card - 2 minutes.
2nd time: yellow card - 5 minutes.
3rd time: yellow/red card - 5 minutes without suspension for the next match.

75.101 Motorcycle not corresponding to the rules

Before the match the Referee examines the motorcycles and gives a warning to the team whose machine(s) is/are not corresponding to the rule and will order them to repair it immediately. If this is not done the machine(s) which do not conform will be removed.

In case of refusal a fine of EURO 30.- for the team and they will lose by default.
Motorcycle(s) without silencers: Fine for the team EURO 30.- and direct exclusion.

75.102 Missing ball(s)

In case a team comes onto the field with only one ball or with none: fine for the team: EURO 10.- per missing ball. This sanction is independent from the sports sanctions provided for.

75.103 Marking-out not done or badly done

Fine for the organising club or FMN: EURO 30.-. This sanction is independent from the sanctions provided by Art. 075.16. These sanctions will be applied, if, after the Referee's examination, the organising club or FMN has not remedied it.

75.104 Entries

The organising club or FMNR will have to mention the price of the entries on a board at the sports ground cash-desk. If this is not done:

1st time: warning to be recorded in the report.
2nd time: fine for the club: EURO 30.-.

75.105 Friendly and international matches

If the indemnity owed to the Referee is not paid, the club will be forced to pay and a 50% surcharge will be added.

75.106 Players on the touch

A Referee may penalise a player by:

- a green card, exclusion from the match for 2 minutes without a substitute. A player may only receive a maximum of 2 green cards per match.
- a yellow card, exclusion from the match for 5 minutes without a substitute. A player may only receive a maximum of 1 yellow card per match.
- a yellow/red card, exclusion from the match for 5 minutes without a substitute. As

a result of this exclusion, the player concerned is automatically suspended for the rest of the match.

- a red card, exclusion from the rest of the match without substitution. As a result of this exclusion, the player concerned is automatically suspended for the next international match independent of any possible sanctions.
- If a Team that is reduced by green, yellow or yellow/red card is receiving a goal, they are allowed to replace the player with the shortest penalty time immediately. This is not valid for red a card.

75.107 Players with a suspended licence

A team playing a match with a player who has a suspended licence automatically loses the match. The suspension is doubled for the suspended player.

Fine for the team: EURO 30.- (coming in addition to the fine already given).

75.108 Incomplete team

A team which presents itself with the minimum of 5 players, with licences, and 5 motorcycles, will be fined EURO 30.- for each player and each motorcycle missing.

75.109 Match stopped by the Referee because one team or both teams refrain from active sporting play

Any match may be stopped by the Referee and one or both teams considered as defeated by default after a previous warning, when it is evident that one or both teams voluntarily refrain from active sporting play, even if one of the teams is stronger than its opponent.

APPENDIX 076 - MOTOBALL EUROPEAN CHAMPIONSHIP SENIOR + JUNIOR CLASS

GENERAL

76.1	Definition	28
76.2	Jurisdiction	28

RULES

76.3	Participants	28
76.4	Players	28
76.5	Equipment of the players and the teams	28
76.6	Classification	29
76.7	Field	29
76.8	Ball	29

ORGANISATION

76.9	Organisation	30
76.10	Organiser	30
76.11	Team composition	30

OFFICIALS

76.12	International Jury	30
76.13	Jury President	31
76.14	Referees	31
76.15	Head of Referees	31

FINANCIAL CONDITIONS AND INDEMNITIES

76.16	Financial conditions and indemnities	31
-------	--------------------------------------	----

GENERAL

In accordance with the 1997 General Assembly decision, the Continental Championships will be run by the respective Continental Unions.

76.1 Definition

The Motoball European Championship for **SENIOR CLASS + JUNIOR CLASS** is held every year between national teams in the same time and place. The Organiser of the European Senior Championship is obliged to organise the European Junior Championship according to the defined Regulations.

The organization of a European championship has to be done during the summer period in July and August.

76.2 Jurisdiction

All Motoball matches have to be organised in accordance with the FIM EUROPE Sporting Code, the Appendix 075 and this Appendix.

RULES

76.3 Participants

All national teams of Europe may play the Motoball European Championship.

The organiser needs to send the Supplementary Regulations to the president of the Motoball Commission - latest 8 months before the championship and the Motoball Commission will answer within one month.

The Supplementary Regulations must receive the FIM Europe Motoball Commission approval.

All participants' nations have to pay a starting money to the Organiser after the confirmation to participate of € 2.000. He gets the money back at Hotel check-out together with the price money, if there were no difficulties in Sport and the Hotel.

76.4 Players

The players must present:

SENIOR CLASS :

- **FIM Europe Motoball Promotional Continental Annual licence.**
- To be eligible for an international licence, a player must be at least 16 years old.

JUNIOR CLASS :

- FIM Europe Promotional Continental One-event licence
- The European Motoball Junior Championship is open to riders that get 12 years of age and who are under, or reach 18 years during the year of the event

Equipment of the players and the teams

Each player of a team must wear a shirt of the same colour, except the goal keeper whose shirt shall be of a different colour. In case of similar colours, one of the

teams must change their shirts. For this reason, each team must bring 2 sets of different colours (except white). A ballot will be made to decide which team has to change their shirt colours.

The players may never wear white. Each player must have a number on the back and front of his shirt. The team must give numbers from 1 to 99 to its players. The numbers must be clearly visible. The numbers on the back must have a minimum height of 25 cm and a minimum width of 17 cm. The width of the stroke must be 5 cm.

On the front the number must be attached to the right-hand side and be 10 cm high and 6 cm wide. The numbers must be of a contrasting colour.

All players must have helmet in one colour.

Each Team needs to present shirts in 2 different colors at the first Jury Meeting and helmets in one colour at the Technical Inspection upfront the Event.

76.5 Classification

The classification of official matches is made by the addition of points as follows:

- 3 points for the winner
- 1 point for a draw
- 0 point for the losing team.

In case of tie, the classification will be made as follows:

- 1) the result of the match between the teams
- 2) the difference of goals scored and received
- 3) maximum goals scored
- 4) if a tie still persists, there will be a series of 4 penalties by 4 different players for each team and then 1 penalty for each team until one team fails to score.
- 5) it will be semi-final games between 1st. and 4th placed teams and between 2nd and 3rd placed teams.
The winner of those semi-finals will go to the final, losers will play 3rd and 4th place game.
- 6) If the event of a tie after the Semi-Finals of the European Championship an extra time about 2x15 minutes for Seniors and 2x10 minutes for Juniors.

76.6 Field

The field used for the European Championship must be of gravel or Asphalt.

76.7 Ball

The ball is a rubber bladder covered with leather or equivalent material. The circumference must be 119 cm minimum and 126 cm maximum. The weight of the ball must be minimum 900 gr and maximum 1200 gr.

Each team must have 4 balls (including 1 white ball). The 4 Balls need to be presented at the Technical Inspection in front of the Event.

ORGANISATION

76.8 Organisation

SENIOR CLASS :

All qualification matches are divided into 4 periods of minimum 15 minutes. The Semi-Finals and Finals will be divided into 4 periods of 20 minutes

JUNIOR CLASS:

All qualification matches are divided into 3 periods of minimum 15 minutes. The Semi-Finals and Finals will be divided into 4 periods of 15 minutes

The game schedule of **SENIOR + JUNIOR CLASS** need to be created according to following scheme depending the number of participants:

7 Teams				6 Teams				5 Teams				4 Teams			
Game				Game				Game				Game			
1	1	-	2	1	1	-	2	1	1	-	2	1	1	-	2
2	3	-	4	2	3	-	4	2	3	-	4	2	3	-	4
3	5	-	6	3	5	-	6	3	5	-	1	3	3	-	1
4	7	-	1	4	1	-	3	4	2	-	4	4	2	-	4
5	2	-	3	5	2	-	5	5	3	-	5	5	4	-	1
6	4	-	5	6	4	-	6	6	4	-	1	6	3	-	2
7	6	-	7	7	5	-	1	7	2	-	3				
8	1	-	3	8	2	-	4	8	4	-	5				
9	5	-	2	9	6	-	3	9	1	-	3				
10	7	-	4	10	1	-	4	10	5	-	2				
11	6	-	1	11	6	-	2								
12	3	-	5	12	3	-	5								
13	2	-	7	13	6	-	1								
14	4	-	6	14	2	-	3								
15	1	-	5	15	4	-	5								
16	7	-	3												
17	6	-	2												
18	4	-	1												
19	5	-	7												
20	3	-	6												
21	4	-	2												

The Organiser is allowed to divide the above game schedule into the number of days the Event will be held. He is allowed to change the game schedule during one day, so that the hosting Team for example will play the last game of the day. This is only allowed if no other Team needs to play 2 games after each other.

The game schedule has to be presented to the Jury President 8 weeks upfront the Event latest and needs his approval.

Before every match the National anthem of the participating teams in the match must be played.

76.9 Organiser

The organisation is the responsibility of the FMNR.

76.10 Team composition

A national Motoball team is made up of 18 persons:

- 10 players
- 2 mechanics
- 2 referees
- 1 manager or trainer
- 1 delegate
- 1 doctor or physiotherapist
- 1 translator to the FIM Europe languages French or English

10 Players can be play after presentation of their licences, more players cannot be nominated later.

A team can be more as 18 persons, but they must pay for a sur plus persons, as more than 18 persons.

The change from 16 to 18 persons will be valid the first time in the year 2018 and will not be changed for the following 7 years.

A team may use a maximum of 10 motorcycles for each match.

OFFICIALS

76.11 International Jury

The International Jury must consist of:

- Jury President (FIM EUROPE Delegate) (voting rights)
- FMNR Jury Member (being the Delegate from the hosting FMN) (no voting rights)
- 1 Delegate from each FMN taking part in the Championship (no player) (voting rights)
- Head of Referees (no voting rights)
- Jury Secretary or Secretary of the meeting (no voting rights)

If the result of a vote will be an draw, the vote of the Jury President counts double.

The 1st Jury meeting must be held before the start of the competition and the others if necessary but anyway on the end of the event.

The 1st Referee meeting must be held before the start of the competition.

76.12 Jury President

The Jury President is appointed by the FIM EUROPE.

76.13 Referees

The Referees are appointed by the participating FMNs (2 Referees for each FMN). They must be in possession of a licence valid for the current year. The minimum age to obtain an international licence is 18 years. The Referee may not also be a Delegate or Manager during the Championship. The Referees have also to guide the Junior Class Games scheduled during the Event.

When a participating FMN is not presenting 2 Referees fulfilling above requirements, they need to pay an penalty of 500 € which will be cut on the price money.

76.14 Head of Referees

The Head of Referees is responsible for the Referees' duties. During the matches, he is responsible to the FIM EUROPE Delegate. He is also responsible to provide the Referee appointments for the matches to the FIM EUROPE Delegate for final approval. He must record all sanctions taken by the Referees against the players. He is not allowed to act as Field Referee or linesman during the Championship. For the Motoball European Championship, the FIM EUROPE standard protocol must be used. The Head of Referees must be in possession of an national Referee-Licence.

FINANCIAL CONDITIONS AND INDEMNITIES

76.15 Financial conditions and indemnities

The promoter will provide for 18 persons of each delegation with:

JUNIOR CLASS :

- Accommodation (Hotel, Youth Hostel, Camping Bungalow, ..) need to be booked by the Organiser from one day before the event until one day after the event for all delegations. Each Delegation need to pay 40€ per night and person to the Organiser. The payment terms need to be defined by the Organiser in the Supplementary Regulations.
- The Organiser need to provide 3 meals per day free of charge.

SENIOR CLASS :

- Accommodation and 3 meals per day free of charge, including one day before the event until one day after the event for all delegations.
- A Dinner on the first evening and a breakfast on the last morning for free.

In addition, the following prize money will be paid to the SENIOR CLASS teams according to the final classification: (in €)

- 1. Place: 1.700 €**
- 2. Place: 1.350 €**
- 3. Place: 1.350 €**
- 4. Place: 1.350 €**



5. Place: 900 €
6. Place: 900 €
7. Place: 900 € ect.

- For the European Championship, the Organiser will provide delegations with a sufficient amount of petrol for the engines at each match.
- The Organiser need to provide cups for place 1 to 3 of the Senior and Junior Championship. The Cup for 1 Place should be around 50cm, but not taller.
- The Organiser need to provide souvenir medals for all participating delegation members.
- The FIM Europe will provide medals for Place 1 to 3 and a Trophy for the European Champion.
- When a Nation will win the Trophy 5 times from 2018 on, they will be allowed to keep the Trophy.

**APPENDIX 077 - Technical Specification
SENIOR + JUNIOR CLASS**

GENERAL

0.77.1	Noise Control	33
0.77.2	Measurement for Noise Control	33
0.77.3	Place for Noise Control	33
0.77.4	Marking of Silencers	33
0.77.5	Engine speed	33
0.77.6	RPM Relation	33
0.77.7	Noise Control table	34
0.77.8	Engines with more than 1 cylinder	34
0.77.9	Presentation of non complying machine	34
0.77.10	After presentation for examination	35
0.77.11	Noise Limits	35
0.77.12	Surrounding for Noise Control	35
0.77.13	Apparatus for Noise Control	35
0.77.14	The response setting	35
0.77.15	Temperature for noise test	35
0.77.16	Noise control after the competition	35
0.77.17	Noise control test during the event	35
0.77.18	Handlebars	35
0.77.19	Suspension	35
0.77.20	Chaincase	36
0.77.21	Mudguard	36
0.77.22	Wheels	36
0.77.23	Engines	36
0.77.24	Brake	36
0.77.25	Ball drive	36
0.77.26	Throttle controls	36

0.77.1 NOISE CONTROL

Noise will be controlled to limits **98 db(A)** for **SENIOR CLASS** and **96 db(A)** for **JUNIOR CLASS** at 15m/s c.

0.77.2 MEASUREMENT FOR NOISE CONTROL

With the microphone placed at 50 cm from the exhaust pipe at an angle of 45° measured from the centre-line of the exhaust end and that height of the exhaust pipe, but at least 20 cm above the ground. If thi is not possible, the measurement can be taken at 45o upwards.

0.77.3 PLACE FOR NOISE CONTROL

During a noise test, machines not equipped with a gear box neutral must be placed on a stand.

0.77.4 MARKING OF SILENCER

The silencers will be marked when they are checked and it is not allowed to change them after verification, except for any spare silencer which has also been checkedand marked.

0.77.5 ENGINE SPEED

The driver shall keep his engine running out of gear and shall increase the engine speed until it reaches the specified RPM range. Measurements must be taken when the specified RPM level is reached.

0.77.6 RPM RELATION

The RPM depends upon the mean piston speed corresponding to the stroke of the engine (see Noise Control table).

The RPMs will be given by the relation

$$n = \frac{30.000 \times cm}{/}$$

In which :

- n = prescribed RPMs of engine
- cm = fixed mean piston speed in m/s
- / = stroke in mm

0.77.7 NOISE CONTROL - RPM FIGURES

Stroke in mm	2-stroke	4-stroke	Stroke in mm	2-stroke	4-stroke
30	13.000	11.000	66	5.909	5.000
31	12.580	10.645	67	5.820	4.925
32	12.187	10.313	68	5.735	4.853
33	11.818	10.000	69	5.652	4.783
34	11.470	9.706	70	5.571	4.714
35	11.142	9.429	71	5.492	4.648
36	10.933	9.167	72	5.416	4.583
37	10.540	8.819	73	5.342	4.521
38	10.263	8.684	74	5.270	4.459
39	10.000	8.462	75	5.200	4.400
40	9.750	8.250	76	5.132	4.342
41	9.512	8.049	77	5.065	4.286
42	9.285	7.857	78	5.000	4.231
43	9.069	7.674	79	4.937	4.177
44	8.863	7.500	80	4.875	4.125
45	8.666	7.333	81	4.815	4.074
46	8.478	7.174	82	4.756	4.024
47	8.297	7.021	83	4.699	3.976
48	8.125	6.875	84	4.643	3.929
49	7.959	6.735	85	4.588	3.882
50	7.800	6.600	86	4.535	3.837
51	7.647	6.471	87	4.483	3.793
52	7.500	6.346	88	4.432	3.750
53	7.358	6.226	89	4.382	3.708
54	7.222	6.111	90	4.333	3.667
55	7.090	6.000	91	4.286	3.626
56	6.964	5.893	92	4.239	3.587
57	6.842	5.789	93	4.194	3.548
58	6.724	5.690	94	4.149	3.510
59	6.610	5.593	95	4.105	3.474
60	6.500	5.500	96	4.063	3.438
61	6.393	5.410	97	4.021	3.402
62	6.290	5.323	98	3.980	3.367
63	6.190	5.238	99	3.939	3.333
64	6.093	5.156	100	3.900	3.300
65	6.000	5.077			

0.77.8 ENGINES WITH MORE THAN 1 CYLINDER

The noise level for engines with more than one cylinder will be measured on each exhaust end.

0.77.9 PRESENTATION OF NON COMPLYING MACHINE

A machine which does not comply with the noise limits can be presented a second im second time.

0.77.10 AFTER PRESENTATION FOR EXAMINATION

When presented for examination, the correct stroke must be stamped in a clearly visible position on the crankcase.

0.77.11 NOISE LIMIT IN FORCE

Motoball: Max. 98 dB/A measured for **SENIOR CLASS** and 96 db(A) for **JUNIOR CLASS** at 15 m/sec. At 5.000 RPM

0.77.12 SURROUNDING FOR NOISE CONTROL

The surrounding noise should not exceed 90 dB/A within 5 metres radius from the power source during tests.

0.77.13 APPARATUS FOR NOISE CONTROL

Apparatus for noise control must be to international standard IEC 651 Type1 or Type 2. The noise meter must be equipped with a calibrator for control and adjustment of the noise meter during periods of use.

0.77.14 THE RESPONSE SETTING

The “slow” reponse setting must always be used.

0.77.15 TEMPERATURE FOR NOISE TEST

Due to influence of temperature on noise tests, all figures are correct at 20°C. For tests taken at temperatures below 10°C there will be + 1dB(A) tolerance and for tests below 0°C + 2 dB(A) tolerance.

0.77.16 NOISE CONTROL AFTER THE COMPETITION

In a competition which requires a final examination of machines before the results are announced, this examination must include a noise control measurement of at least the first three machines listed in the final classification. At this final test for track racing, there will be a 1 dB/A tolerance.

0.77.17 NOISE CONTROL TEST DURING THE EVENT

In a competition which requires noise control tests during the event, machines must comply with the noise limits without tolerance.

0.77.18 HANDLEBARS

The length of the handlebars is 70 cm max. incl. hand protection. Clip-on handlebars are forbidden. Handlebar ends may not facing forward and must end with rubber plugged or a protection with an equivalent material.

0.77.19 SUSPENSION

0.77.20 CHAINCASE

Chainguard must protect the rear chain at the countershaft sprocket and at the rear sprocket.

0.77.21 MUDGUARD

If the front wheel is protected by a mudguard, it must not be more than 100 mm between the wheel and mudguard.

The rear mudguard must not extend beyond the vertical line drawn at a tangent to the rear edge of the rear tyre.

0.77.22 WHEELS

The front and rear wheels for **SENIOR CLASS** must be between 16" and 19" rim diameter. For **JUNIOR CLASS** smaller wheels are allowed. Forged or casted wheels are only allowed if the sides are completely closed by protectors

As rear tyres may use Trial or Speedway or tyres which have a distance of profile less than the profile burl size. Front tyres are optional.

0.77.23 ENGINE

SENIOR CLASS:

Motoball motorcycle engines must not exceed 250 ccm - 2 or 4 stroke. Electric bikes are allowed also.

The engine must be equipped with a silencer. The number of decibels must not exceed the limit in Art. (98dBA).

JUNIOR CLASS :

Motoball motorcycle engines must not exceed 85 ccm for 2 and 150ccm for 4 stroke. Electric bikes are allowed also.

The engine must be equipped with a silencer. The number of decibels must not exceed the limit in Art. (96dBA).

When losing a silencer the motorcycle must immediately leave the field.

0.77.24 BRAKE

The motorcycle must equipped with front brake operated by handlebar lever. The rear brake must be operated by 2 pedals (1right pedal and 1 left pedal).

0.77.25 BALL DRIVE (SEE DIAGRAMM 1a + 1b)

Motorcycle must be equipped with a ball drive to avoid the ball being embedded between the front wheel and the engine. The ball drive, fitted to the frame, must be roughly 100 mm away the mudguard, or the front wheel.

The ball drive also serves as an engine protection in order that nor parts (brake pedals, start lever etc.) go beyond it. A second system of ball drive is allowed, called mechanical system for arcs (see drawings Ia) and alternative Ib), at both Ball drive systems is the maximum wide 440 mm.

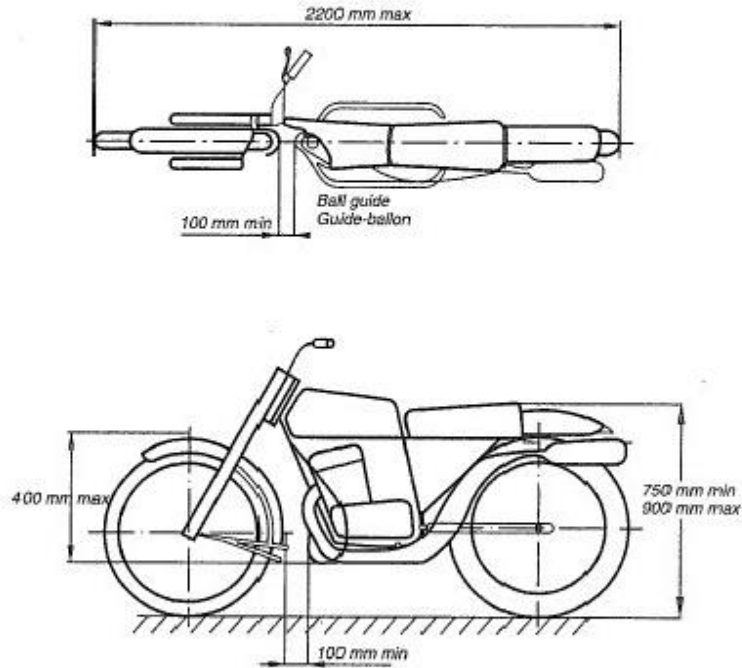
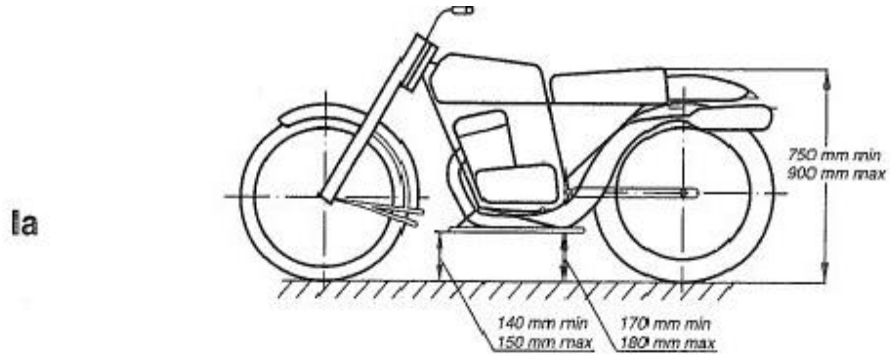

0.77.26 THROTTLE CONTROLS

Throttle controls must be self closing in order that the machine slows down or stops in case of a fall.